

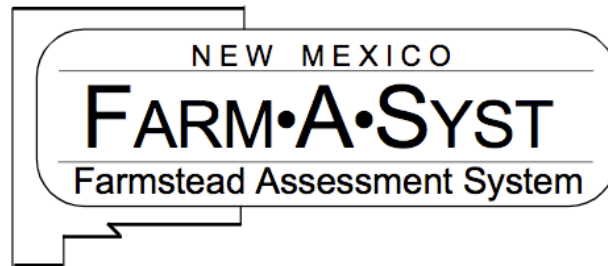

Fact Sheet #6
*Reducing the Risk of Groundwater Contamination by
Improving Household Wastewater Treatment*





Fact Sheet #6

Reducing the Risk of Groundwater Contamination by **Improving Household Wastewater Treatment**

A properly installed and maintained system for treating and disposing of household wastewater will minimize the impact of that system on groundwater and surface water. State and local codes specify how wastewater systems must be designed, installed and maintained. New Mexico Environment Department regulates private sewage systems under the Liquid Waste Disposal Regulations.

At a minimum, follow the codes. But also consider whether the minimum requirement is sufficient for your site.

Septic tank/soil absorption system: The most common system

The most common form of onsite wastewater treatment is a septic tank/soil absorption system. In this system, wastewater flows from the household sewer into an underground septic tank.

- There the waste components separate—the heavier solids (sludge) settling to the bottom, and the grease and fatty solids (scum) floating to the top.
- Bacteria partially decompose and liquify the solids.
- Baffles are placed in the tank to provide maximum retention of solids, prevent inlet and outlet plugging, and prevent rapid flow of wastewater through the tank.
- The more liquid portion (effluent) flows through an outlet to the soil absorption field.
- The absorption field is usually a series of parallel trenches (fingers), each containing a distribution pipe embedded in drainfield gravel or rock.
- The effluent leaks out through holes in the pipe, then down through the drainfield gravel or rock and into the soil.
- The soil filters out remaining minute solids and pathogens (disease-producing microorganisms), and dissolved substances slowly percolate down to groundwater.

*For glossary,
see Worksheet
#6.*

1. Quantity of wastewater

Strategy: Minimize the volume of household wastewater.

Reducing the volume of wastewater entering the treatment system is important because less flow (volume) means better treatment, longer system life and less chance of overflow. For holding tanks, less volume reduces costs by reducing the number of times the tank has to be emptied.

The quantity of water used depends upon the number of people using the dwelling, how water is used, and maintenance of the water supply system. Average water use in rural households is 40-50 gallons per person per day. With low-use fixtures and individual awareness and concern, a reduction to fewer than 25 gallons per person per day is possible. However, even conservative use by several people may exceed the capacity of the wastewater treatment system.

Reducing the volume of water entering the system will improve the treatment by increasing the time the waste spends in the system, thus providing more time for settling, aeration and more soil contact.

Consider the following ways to minimize water use:

- Eliminate non-functional uses, such as flushing toilets to dispose of tissues or other wastes that should be handled as solid waste. Turn off water between uses, fix plumbing fixture leaks, and try to eliminate sources of clear water and infiltration into the system. (For example, divert roof drains away from the soil absorption field.)
- Consider which actions use the most water. Toilet flushing usually ranks highest. Low-flow models could decrease water use by more than half. In the United States, 35-40 percent of the population has plumbing codes that require 1.5-gallon-or-less toilets on all new construction. Composting toilets allow even greater reductions, but they can present other waste disposal challenges.
- Bathing and clothes washing are next in order of water use. For bathing, consider such reduction options as installing low-flow or controlled-flow showerheads, which give good cleansing with less water; taking shorter showers; and taking “wet-down-soap-up-without-water-then-rinse” showers.
- For clothes washing, use a suds saver and run full loads. Front-loading washers use much less water. When running small loads, be sure to use the reduced water level setting.
- Modern efficient plumbing fixtures, including 0.5 to 1.5-gallon toilets, 0.5-2.0 gallons per minute (gpm) showerheads, faucets of 1.5 gpm or less, and front-loading washing machines of 20 to 27 gallons per 10-to-12-pound dry load, offer the potential of substantial reduction in residential water use and wastewater generation. These reductions have commonly amounted to between 30 and 70 percent of total in-house water use (See Figure 1).
- In hard water areas, the water softener may be a significant user of water. Proper adjustment and timing of the softener’s regeneration mechanism can reduce excessive water use.
- Keep in mind that awareness of your family’s water use and how each of you can reduce it is as important as the use of water conservation devices.

Figure 1: Water Use by Conventional Fixtures and Water-Saving Fixtures and Devices

| Conventional fixture | Gal. used | Water-saving fixture/device* used | Gal. used |
|----------------------------------|------------|------------------------------------------------------|----------------------|
| Toilet | 4-6/flush | Air-assisted toilet | 0.5/flush |
| Shower head | 4-6/min. | Low-flow shower head | 2.0/min. |
| Faucets: Bathroom and kitchen | 4-6/min. | Faucet-flow-control aerators: Bathroom Kitchen | 0.5/min. 1.5/min. |
| Top-loading clothes washer | 40-55/load | Front-loading clothes washer | 22-33/load |

*Installation of all these water-saving devices could reduce water use by about 35%.

Source: Penn State Cooperative Extension Circular 302

2. Quality of wastewater

Strategy: Minimize the amount and complexity of contaminants in the waste-water.

The quality of water refers to what is in the water, not to the water itself. Even wastewater is more than “99.44% pure” water. Wastewater usually contains relatively small amounts of contaminants—but they make a big difference in the usefulness of the water.

Contaminants found in wastewater include:

- **Bacteria and viruses**, some of which can cause disease in humans. Most bacteria are large enough to be removed by settling, or through filtration in beds or soil. Many will die from the adverse conditions or aging in the system. Viruses may attach to soil particles, but may be released heavy rains.
- **Suspended solids**, particles which are more dense (sludge) or less dense (scum) than water. Most can be separated from liquid waste by allowing enough time in a relatively calm tank. Grease and fats are a part of the suspended solids. Filtration beds and absorption systems can be clogged by wastewater high in suspended solids.
- **Oxygen demand**. The microorganisms that decompose organic wastes use oxygen. The amount of oxygen required to “stabilize” wastewater is typically measured as biochemical and chemical “oxygen demand.” Wastes such as blood, milk residues and garbage grindings have high oxygen demand. Aeration and digestion processes, in the presence of oxygen and organisms, produce stable, low-odor wastewater when given enough time. Wastewater with excess oxygen demand can cause problems for soil absorption fields, groundwater, streams and lakes by reducing levels of oxygen.

- **Organic solvents** from cleaning agents and fuels may not be degraded or removed through treatment and can pass along with the wastewater back into the groundwater. These compounds may also interfere with digestion in the septic tank.
- **Nutrients.** Nitrogen from human wastes and phosphorus from machine dishwashing detergents and some chemical water conditioners are the most notable. Nitrate-nitrogen is a common groundwater contaminant, and phosphorus overfertilizes surface water.

Consider the following ways to improve wastewater quality:

- Minimize use of the garbage disposal unit. Garbage disposal use contributes a large load of suspended solids and organic matter to wastewater, as well as using additional water.
- Do not put items down drains that may clog septic tanks (fats, grease, coffee grounds, paper towels, sanitary napkins, tampons, disposable diapers).
- Do not put toxic substances in drains that might end up in the groundwater, such as solvents, degreasers, acids, oils, paints, disinfectants and pesticides. (This does not include using bleach to disinfect laundry or to wash clothing worn for pesticide applications.)
- Do not use chemicals to clean or “sweeten” your system. They may interfere with the biological action in the tank, clog the drain field by flushing sludge and scum into the field or add toxic chemicals to groundwater.

3. Collection of wastewater

Strategy: Collect all wastes that need treatment. Minimize loss of untreated waste. Exclude from the treatment system water that doesn't need treatment or disposal.

Leaking piping or treatment tanks (“leakage losses”) can allow wastewater to return to the local water supply without adequate treatment. Infiltration of clear water overloads the system and dilutes the wastes. Don't allow water that doesn't need treatment (foundation drains, infiltration of rain water, roof drainage) to add to your waste volume. Divert clear water, which doesn't require treatment, away from house, well and wastewater treatment system.

4. Pretreatment system

Strategy: Make wastewater more suitable for further treatment or disposal.

Septic tanks retain most of the suspended solids (sludge and scum) from wastewater. In the tank, bacteria digest and compact the sludge. The partially treated water moves on to additional treatment or disposal (for example, in a soil absorption field.)

Design and construction of septic tanks influence their water tightness and effectiveness of retaining sludge and scum. Multiple tanks or chambers in series improve sludge and scum removal. Gas deflectors and filter screens or inclined-plate settling units help to minimize solids carryover. Tanks should be sized to accommodate at least 24 hours of wastewater flow, while still allowing for sludge and scum retention. Pumping the tank before it is more than one-third filled with scum and sludge improves functioning of the system. When the tank is pumped, you should also have the baffles checked and check for tank leaks.

Aerobic (oxygen-using) biological systems (packaged systems) provide more extensive treatment of wastewater than the typical anaerobic (no oxygen) septic units, improving solids separation, releasing volatile chemicals and reducing sludge volume. These systems are, however, more expensive to operate and maintain and are more subject to problems caused by changes in wastewater quality or environmental conditions.

Holding tanks collect and hold the entire wastewater flow. Disposal is generally done by a licensed contractor who spreads the waste on the land at an approved site or hauls it to a municipal waste treatment facility. Tank size should allow for ample capacity to accommodate pumpage and disposal at convenient and appropriate times, especially for land spreading. When pumped, the tank should be checked for leaks.

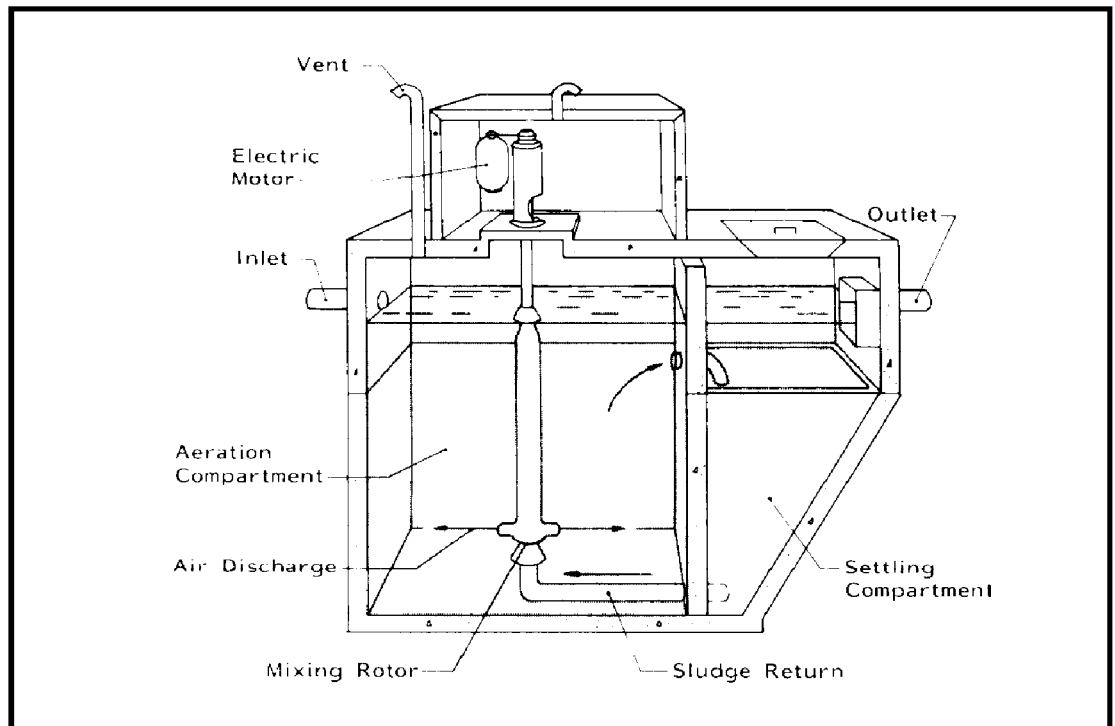

Figure 2: Aeration tank of a household aerobic treatment system. Source: *Onsite Domestic Sewage Disposal Handbook, MWPS-24, Midwest Plan Service, 1982.*

5. Additional treatment

Strategy: Reduce concentration and amount of contaminants in the wastewater to expand options for appropriate disposal.

Aerobic systems, described in the previous section, may be used for additional treatment of septic tank effluent, yielding a better quality effluent suitable for more disposal options.

Sand filters improve the quality of wastewater after septic tank pretreatment. Effective treatment involves aerobic biochemical activity as well as physical filtration. Filters consist of 2 to 5 feet of sand (or other media) in a bed equipped with a distribution and collection system. Wastewater is applied by dosing, and it may be recirculated to improve treatment.

Wastewater treated in such systems is generally lower in bacteria, nitrogen, phosphorus, oxygen demand, suspended solids and organic matter. The amount of reduction depends on design of the system.

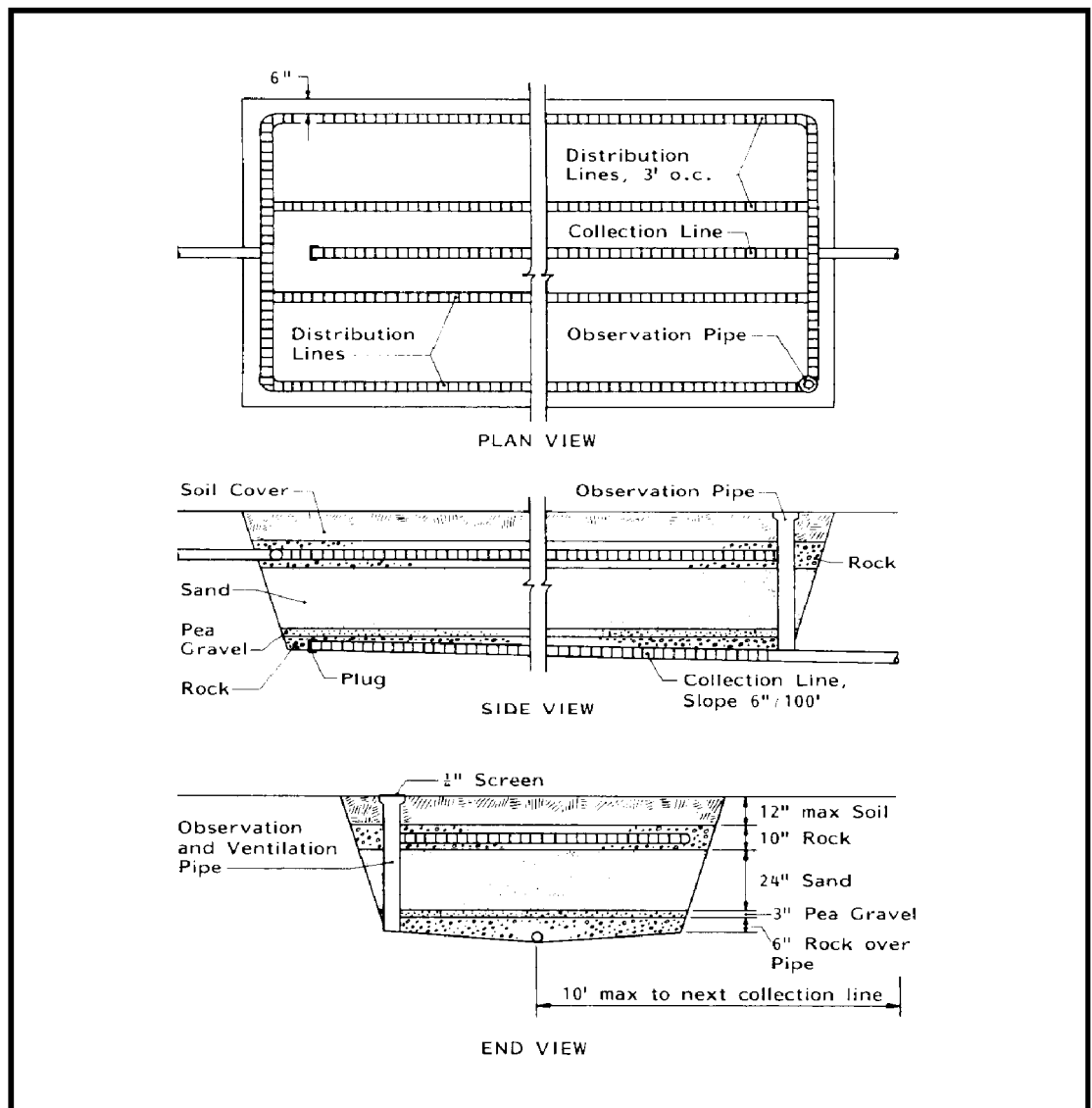

Figure 3: Buried sand filter. Source: *Onsite Domestic Sewage Handbook, MWPS-24, Midwest Plan Service, 1982.*

Pretreatment and quality of wastewater, hydraulic loading rate, depth and type of filter media, dosing frequency, temperature and distribution, and collection systems are all important considerations in designing filters. Maintenance includes resting, occasional raking, removal of clogged and crusted surface media, filter media replacement and attention to dosing equipment.

Nitrogen removal can be achieved through denitrification (conversion of nitrate to nitrogen gas) or ion exchange. Denitrification requires anaerobic conditions in the presence of more decomposable organic matter for bacteria to reduce nitrate to nitrogen gas for removal from wastewater. Denitrification and ion exchange processes are not used extensively at this time, as they are quite expensive to install, operate and maintain.

Disinfection systems kill disease-causing microorganisms in wastewater. Chlorine, iodine, ozone and ultraviolet light systems are available for disinfection of good quality effluents, such as those from properly functioning aerobic units and sand filters.

6. Disposal of wastewater and pumpage

Off-site disposal of wastewater, by connection to a municipal sewage system or hauling to a municipal treatment facility, can help protect the local farmstead water supply. Discharging treated wastes from private systems to surface water, washes or arroyos requires special permits and monitoring of effluent quality. Improper waste management off the farm site can endanger the health of others in your community, and may eventually contribute to poor water quality at your well.

Subsurface treatment and disposal using soil absorption (trenches, beds, mounds, at-grade and gravelless) is the common practice for household wastewater after pretreatment in a septic tank or aerobic system. There are, however, sites where soil absorption systems are not acceptable because of high or low soil permeability, depth to bedrock or the saturated zone, or other factors. Deep, well-drained, well-developed, medium-textured soils (such as silt loam and loam) are desirable soil absorption sites.

Surface treatment and disposal systems, such as constructed wetlands or evaporation beds are alternatives if a soil absorption system is not feasible. These systems must be designed, installed, and maintained correctly to be effective. Site characteristics (soil, land use, depth to groundwater, weather, climate and hydrogeology) should be considered when selecting a site.

Soils and separation from the water supply are important factors. Unsaturated soils allow movement of air, helping keep the wastewater aerobic. A minimum of four-feet of unsaturated soils is required for removal of bacteria. Finer-textured soils (clay loams and clay) retain water better, allowing plant roots to take up wastewater and nutrients and allowing increased die-off of microorganisms. Coarse, sandy soils allow effluent to flow too quickly downward to groundwater, not providing adequate time for filtering solids and pathogens from the liquid. Disposal sites that are more distant and downslope from the well increase the isolation of your water supply from the contaminated wastewater.

Disposal of pumpage from septic tanks and land application of wastewater and sludge must only be done on sites permitted by the Environment Department. Approved sites for land application must meet requirements found in Water Quality Control Commission Regulations, including requirements for soil, depth to groundwater or bedrock, slope and distance from well and residences.

7. Assistance with failing systems or new designs

If you suspect your household wastewater treatment system is backing up or your distribution system is clogged, first contact your plumber or treatment system installer, who may have suggestions for extending the life of your system. Contact your local Environment Department Field Office for permits to repair or replace your wastewater treatment system.

Do not use septic tank cleaners that contain degreasing solvents like TCE. They can contaminate groundwater.

Do not place more soil over a surfacing soil absorption field; this does not fix the system, and it will soon surface again.

Do not pipe the sewage to the road ditch, storm sewer, stream or farm drain tile; this pollutes the water and creates a health hazard.

Do not run the sewage into a sink hole or drainage well; this pollutes the groundwater.

Do not wait for the system to fail before pumping the septic tank. Once a system fails, it is too late to pump the tank.

A properly designed, constructed and maintained septic system can effectively treat wastewater for many years. For more information on septic systems, or alternative wastewater treatment systems, contact your county Extension agent or local Environment Department field office.